

Detroit Radiant Products Co.

PH Series Manual



Installation, Operation, Maintenance and Parts



All persons involved with the installation, operation and maintenance of the heater system must read and understand the information in this manual.

⚠ WARNING



Improper installation, adjustment, alteration, service or maintenance can cause property damage, injury or death. Read and understand the installation, operating and maintenance instructions thoroughly before installing or servicing this equipment.

This heater must be installed and serviced by trained gas installation and service personnel only. Inspect the heater annually. Failure to comply could result in personal injury, asphyxiation, death, fire and/or property damage.



Not for indoor residential use. This heater is not approved for use in any indoor residential application. This includes, but is not limited to, attached garages, solarium, living quarters, etc. Installation in residential indoor spaces may result in property damage, asphyxiation, serious injury or death.



Storage of gasoline and other flammable vapors and liquids in the vicinity of this or any other appliance may result in fire or explosion. Do not store or use gasoline or other flammable vapors and liquids in the vicinity of this or any other appliance. Maintain clearance to combustibles.

For Your Safety

If you smell gas:

- Shut off gas to the appliance.
- Extinguish any open flame.
- Do not try to light any appliance.
- Do not touch any electrical switch.
- Call your gas supplier. Do not use any phone in your building.
- Follow the gas supplier's instructions.
- If you cannot reach your gas supplier, call the fire department.

Keep these instructions for future reference.

Contents

- 1.0 Safety 3**
 - Warning Symbols 3
 - Applications 3
 - Clearance to Combustibles 4
 - Gas Connection. 6
 - Standards, Certifications and Government Regulations 6
 - Safety Signs and Labels 8
- 2.0 Installation 9**
 - Design 9
 - Heater Mounting 11
 - Gas Supply 13
 - Electrical Requirements 16
 - Ventilation 17
- 3.0 Operation 18**
 - Sequence of Operation 18
 - Wiring Diagrams 19
- 4.0 Maintenance 20**
 - Periodic Maintenance 20
 - Troubleshooting Guide 21
- 5.0 Parts 22**
- 6.0 Limited Warranty 24**

1.0 Safety

⚠ WARNING



Improper installation, adjustment, alteration, service or maintenance can cause property damage, serious injury or death. Read and understand, the installation, operating and maintenance instructions thoroughly before installing or servicing this equipment. Only trained, qualified gas installation and service personnel may install or service this equipment.

Warning Symbols

Safety is the most important consideration during installation, operation and maintenance of the infra-red heater. You will see the following symbols and signal words when there is a hazard related to safety or property damage.

⚠ WARNING

Warning indicates a potentially hazardous situation which, if not avoided, could result in death or injury.

⚠ CAUTION

Caution indicates a potentially hazardous situation which, if not avoided, could result in minor or moderate injury.

NOTICE

Notice indicates a potentially hazardous situation which, if not avoided, could result in property damage.

Applications

This is not an explosion proof heater. Consult your local Fire Marshall, insurance carrier and other authorities for approval of the proposed installation.

Commercial / Industrial

Infra-red heaters are designed and certified for use in industrial and commercial buildings such as outdoor restaurant patios, warehouses, manufacturing plants, aircraft hangars and vehicle maintenance shops. For maximum safety, the building must be evaluated for potential hazards before installing the heater system. A critical safety factor to consider before installation is the clearance to combustibles.

Outdoor Residential

This heater may only be used in outdoor residential applications and is **NOT** approved for use in any indoor residential application. This includes, but not limited to, attached garages, living quarters, solarium, etc. Consult the local fire marshal and/or insurance provider if unsure of your application.

⚠ WARNING



Not For Indoor Residential Use. Installation of a infra-red heater system in residential indoor spaces may result in property damage, serious injury or death. In residential applications this heater may only be used outdoors.

Clearance to Combustibles

⚠ WARNING



Improperly connected gas lines may result in serious injury or death, explosion, poisonous fumes, toxic gases, asphyxiation. Connect gas lines in accordance to national, state, provincial and local codes.



Placement of explosive objects, flammable objects, liquids and vapors close to the heater may result in explosion, fire, property damage, serious injury or death. Do not store, or use, explosive objects, liquids and vapor in the vicinity the heater.



Failure to comply with the published clearances to combustibles could result in personal injury, death and/or property damage.



In locations used for the storage of combustible materials, signs must be posted to specify the maximum permissible stacking height to maintain the required clearances from the heater to the combustibles. Signs must either be posted adjacent to the heater thermostats or in the absence of such thermostats, in a conspicuous location.

Hazards Include:

For maximum safety the building must be evaluated for hazards before installing the heater system. Examples include, but not limited to:

- Gas and electrical lines
- Combustible and explosive materials
- Chemical storage areas
- Areas of high chemical fume concentrations
- Provisions for accessibility to the heater
- Adequate clearances around air openings
- Combustion and ventilating air supply
- Vehicle parking areas
- Vehicles with lifts or cranes
- Storage areas with stacked materials
- Lights
- Sprinkler heads
- Overhead doors and tracks
- Dirty, contaminated environment

A critical safety factor to consider before installation is the clearances to combustibles. Clearance to combustibles is defined as the minimum distance you must have between the infra-red surface, or reflector, and the combustible item. Considerations must also be made for moving objects around the infra-red heater. The following is a partial list of items to maintain clearances from:

Combustible items:

- Wood
- Paper
- Fabric
- Chemicals
- Wall or roof insulation

Moving Objects:

- Overhead doors
- Vehicle lifts
- Cranes
- Hoists
- Car wash equipment

When installing the infra-red heater system, the minimum clearances to combustibles must be maintained. These distances are shown in Chart 1.1 and on the minimum clearance to combustibles label (F/N: LLPCL002) found on the heater. If you are unsure of the potential hazards, consult your local fire marshall, fire insurance carrier or other qualified authorities on the installation of gas fired infra-red heaters for approval of the proposed installation.

Chart 1.1 • Clearance to Combustibles in Inches (see Figure 1.1)

Model No.	Mounting Angle*	Sides	Back	Top	Below	End(s)	Front
PH 28 (-SS) 28,000 [N,P]	0°	14	N/A	13	46	22	N/A
	30°	N/A	8	17	46	22	46
PH 31 (-SS) 31,000 [N,P]	0°	14	N/A	13	46	22	N/A
	30°	N/A	8	17	46	22	46
PH 34 (-SS) 34,000 [N,P]	0°	14	N/A	13	46	22	N/A
	30°	N/A	8	17	46	22	46

* Heaters mounted on an angle between 0° to 30° must maintain clearances posted for 0° or 30°; whichever is greater.

Important! If the heater is mounted beneath a non-combustible surface an 8 in. minimum top clearance must be maintained from the top of the heater to prevent overheating the controls.

Clearance to combustible distances represent a surface temperature of 90°F (32°C) above ambient. Ensure that building materials with a low heat tolerance (i.e, awnings, fabrics, plastics, sprinklers, insulation) are protected against degradation. This may require the heater to be mounted at a distance in excess of the published clearances to combustibles. Contact the factory.

Figure 1.1 • Clearance to Combustibles

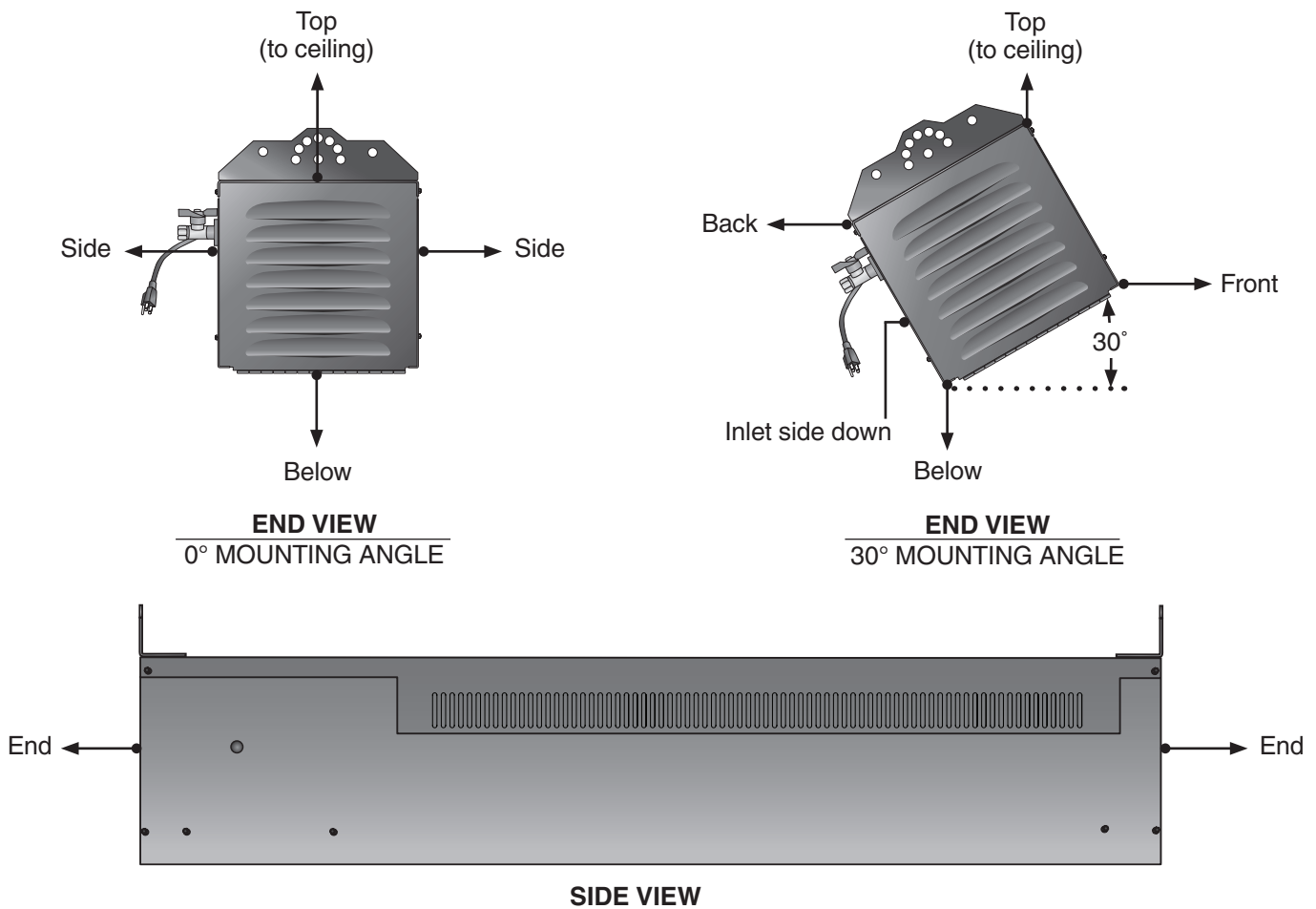

IMPORTANT: Fire sprinkler heads must be located at an appropriate distance from the heater. This distance may exceed the published clearance to combustibles. Certain applications will require the use of high temperature sprinkler heads or relocation of the heaters.

Potentially flammable substances, such as Propylene Glycol or antifreeze solutions, are not to be used in conjunction with this heater.

For further information consult NFPA 13. Always observe applicable state and local codes.

Gas Connection

WARNING

An approved connector, suitable for the environment of equipment usage, is required. Visible or excessive swaying, flexing and vibration of the gas connections must be avoided to prevent failure. Neither the gas pipe nor the connector shall be placed in the flue discharge area or in direct contact with infrared rays. In no case shall the gas supply support or bear weight of the heater.

To ensure your safety, and comply with the terms of the warranty, all units must be installed in accordance with these instructions.

Standards, Certifications and Government Regulations

Installation of this infra-red heater **must** comply with all applicable local, state and national specifications, regulations and building codes. Contact the local building inspector and/or fire marshall for guidance.

In the absence of local codes, the installation must conform to the latest edition of the National Fuel Gas Code, ANSI Z223.1 (NFPA 54).

Chart 1.2 • Standards and Code Installation Guidelines • Building Aspect

Building Aspect	Codes And Guidelines
Electrical	The heater must be electrically grounded in accordance with the following codes: Refer to National Electrical Code®, ANSI/NFPA 70 (latest edition). Wiring must conform to the latest edition of National Electrical Code®, local ordinances, and any special diagrams furnished.
Venting	Unvented heater must meet ventilation requirements. See page 17.

Chart 1.3 • Standards and Code Installation Guidelines • Building Type

Building Type	Codes And Guidelines
Public Garages	<p>Installation of this infra-red heater in public garages must conform to the following codes:</p> <p>Standard for Parking Structures NFPA 88A (latest edition) or the Code for Motor Dispensing Facilities and Repair Garages NFPA 30A (latest edition).</p> <p>Guidelines:</p> <ul style="list-style-type: none"> • Heaters must not be installed less than 8 ft. (2.4 m) above the floor. Minimum clearances to combustibles must be maintained from vehicles parked below the heater. • When installed over hoists, minimum clearances to combustibles must be maintained from the upper most point of objects on the hoist.
Aircraft Hangars	<p>Installation of this infra-red heater in aircraft hangars must be in accordance with the following codes:</p> <p>Refer to Standard for Aircraft Hangars, ANSI/NFPA 409 (latest edition).</p> <p>Guidelines:</p> <ul style="list-style-type: none"> • In aircraft storage and servicing areas, heaters shall be installed at least 10 ft. (3 m) from above the upper surface of wings or of the engine enclosures of the highest aircraft that may be housed in the hangar. The measurement shall be made from the wing or engine enclosure, whichever is higher from the floor, to the bottom of the heater. • In areas adjoining the aircraft storage area (e.g., shops, offices) the bottom of heaters shall be installed no less than 8 ft. (2.4 m) above the floor. • Suspended or elevated heaters shall be located in spaces where they shall not be subject to damage by aircraft, cranes, movable scaffolding or other objects. <p>Provisions shall be made to assure accessibility to suspended infra-red heaters for recurrent maintenance purposes.</p>

Detroit Radiant Products Units comply or are certified by one or more of the following organizations or standards:

- CSA International Requirement (CSA 2.37/5.90 U.S.).
- American National Standards Institute (ANSI Z83.26).

Safety Signs and Labels

It is important to provide warnings to alert individuals to potential hazards and safety actions. ANSI Z83.26/CSA 2.37 require you to post a sign “specifying the maximum permissible stacking height to maintain the required clearances from the heater to the combustibles” near the heaters thermostat or in absence of such thermostats in a conspicuous location.

Safety warning labels must be maintained on the infra-red heater. Illustrations of the safety labels, and their locations, are pictured below. In locations used for the storage of combustible materials, signs must be posted to specify the maximum permissible stacking height to maintain the required clearances from the heater to combustibles. Signs must either be posted adjacent to the heater thermostats or in the absence of such thermostats in a prominent location.

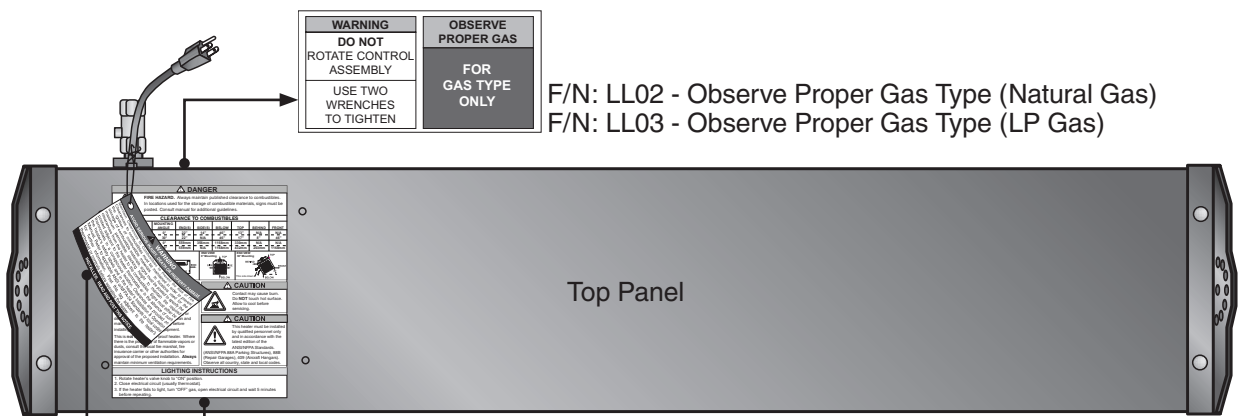

WARNING
DO NOT ROTATE CONTROL ASSEMBLY
USE TWO WRENCHES TO TIGHTEN

OBSERVE PROPER GAS
FOR GAS TYPE ONLY

F/N: LL02 - Observe Proper Gas Type (Natural Gas)
F/N: LL03 - Observe Proper Gas Type (LP Gas)

Top Panel

WARNING
AVOID SERIOUS INJURY, DEATH OR PROPERTY DAMAGE.

Maintain Clearances to Combustibles to Prevent the Risk of Fire. Clearances to combustibles must be maintained in order to prevent the ignition of combustible materials. In locations used for the storage of combustible materials, signs must be posted to specify the maximum permissible stacking height to maintain the required clearances from the heater to the combustibles. Signs must either be posted adjacent to the heater thermostats or in the absence of such thermostats in a conspicuous location. Clearances are provided on the heater's safety labels and in the heater's Installation & Operation Manual. Refer to applicable ANSI or NFPA-54 Standards or local codes for further information. Post this tag adjacent to the heater's thermostat or controls before operating the heater.

INSTALLER. READ AND POST THIS NOTICE.

F/N: LL01 - Clearance Safety Tag
(Affix adjacent to heater's thermostat).

DANGER
FIRE HAZARD. Always maintain published clearance to combustibles. In locations used for the storage of combustible materials, signs must be posted. Consult manual for additional guidelines.

CLEARANCE TO COMBUSTIBLES

MODEL NO.	MOUNTING ANGLE	END(S)	SIDE(S)	BELOW	TOP	BEHIND	FRONT
ALL MODELS	0°	22"	14"	46"	13"	N/A	N/A
	(in inches)	30"	22"	N/A	46"	17"	8"
ALL MODELS	0°	559mm	356mm	1168mm	330mm	N/A	46"
	(in millimeters)	30"	559mm	N/A	1168mm	432mm	203mm

WARNING
Avoid Serious Injury or Death. Improper installation, adjustment, alteration, service or maintenance can cause property damage, injury or death. Read the installation, operation and maintenance manual thoroughly before installing or servicing this equipment. This is **not** an explosion-proof heater. Where there is the possibility of flammable vapors or dusts, consult the local fire marshal, fire insurance carrier or other authorities for approval of the proposed installation. **Always** maintain minimum ventilation requirements.

CAUTION
Contact may cause burn. Do **NOT** touch hot surface. Allow to cool before servicing.

CAUTION
This heater must be installed by qualified personnel only and in accordance with the latest edition of the ANSI/NFPA Standards. (ANSI/NFPA 88A Parking Structures), 88B (Repair Garages), 409 (Aircraft Hangars). Observe all country, state and local codes.

LIGHTING INSTRUCTIONS

1. Rotate heater's valve knob to "ON" position.
2. Close electrical circuit (usually thermostat).
3. If the heater fails to light, turn "OFF" gas, open electrical circuit and wait 5 minutes before repeating.

F/N: LLPCL002
Patio Heater Clearance
to Combustibles Label

2.0 Installation

⚠ WARNING



Read and understand, the installation, operating and maintenance instructions thoroughly before installing or servicing this equipment.

Only trained, qualified gas installation and service personnel may install or service this equipment.

⚠ CAUTION

This heater cannot be used in a building with a roof that is not insulated or where condensation problems can occur.

NOTICE

Radiant heat is capable of damaging or destroying certain materials or items. Do not store material or items underneath the heater. Always maintain clearance to combustibles.

Design

To ensure a safe, properly designed heating system, a layout should be developed for the correct placement of the infra-red heater(s). Aside from safety factors such as clearance to combustibles (see Chart 1.1 on page 5), you should take into consideration:

- The environment (e.g., is it cold/drafty, average, protected)?



NOTE: The effective infra-red surface temperature of a person or object may be diminished with wind above 5 mph, wind barriers may be required.

- What is the area of heat coverage (e.g., sq. ft.) needed (Chart 2.1, Figure 2.2)?
- Is the heater being used in a social gathering area, or work station(s)?
- The mounting height of the heater (Chart 2.1, Figure 2.2).
- The type of mounting to be used.
- Physical space needed for the heater (Figure 2.1).
- Gas supply and connections.
- Combustion, ventilating air supply and exhaust path.
- Electricity and wiring to the heater.

IMPORTANT: Fire sprinkler heads must be located at an appropriate distance from the heater. This distance may exceed the published clearance to combustibles. Certain applications will require the use of high temperature sprinkler heads or relocation of the heaters.

Sprinkler systems containing propylene glycol or other flammable substances are not to be used in conjunction with this heater without careful consideration for and avoidance of potential fire or explosion hazards. For further information consult NFPA 13. Always observe applicable state and local codes.

Figure 2.1 • Heater Dimensions

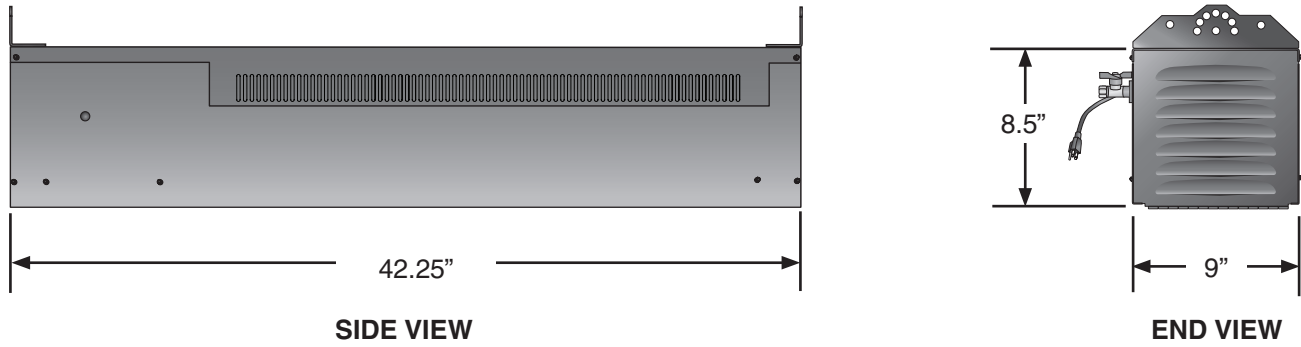

Chart 2.1 • Recommended Mounting Heights

Model & Input	Recommended Mounting Height (Dim. A)	Approximate Coverage Area	Approx. Coverage (sq. ft.)
PH-28 28,000 BTU/H	8'-0" to 8'-6"	7' x 7'	49 sq. ft.
PH-31 31,000 BTU/H	8'-0" to 9'-0"	8' x 8'	64 sq. ft.
PH-34 34,000 BTU/H	8'-6" to 10'-0"	9' x 9'	81 sq. ft.

Note: This chart is provided as a guideline. Actual conditions dictate variances from this data.

Figure 2.2 • Recommended Mounting Heights



Heater Mounting

⚠ WARNING



Improper suspension of the infra-red heater may result in collapse and persons being crushed. Always suspend from a permanent part of the building structure that can support the total force and weight of the heater.



Failure to maintain minimum clearance to combustibles may result in fire and/or explosion, property damage, serious injury or death. Always maintain minimum clearances and post signs or provided tags (F/N: LL01) where needed. Signs should state the hazards for the particular application and be legible for the building occupants. Consult the factory or a factory representative for additional information on signage compliance.

The heater can be suspended with chains or rigid threaded rod. Local codes, or conditions such as wind drafts or other variables can cause movement of the heater and may require rigid threaded rod. Avoid excessive movement and/or vibration of the gas connection by rigidly mounting the heater (see Figure 2.4). The Detroit Radiant optional patio heater mounting brackets (P/N: PH-BKT) can be used in place of rigid threaded rods. Consult all applicable codes before installation.

The heater must be level from side to side and can be set at an angle between 0° and 30° from horizontal. The gas connection and power cord **must** be located on the lower side (see Figure 2.3).

Figure 2.3 • Heater Orientation

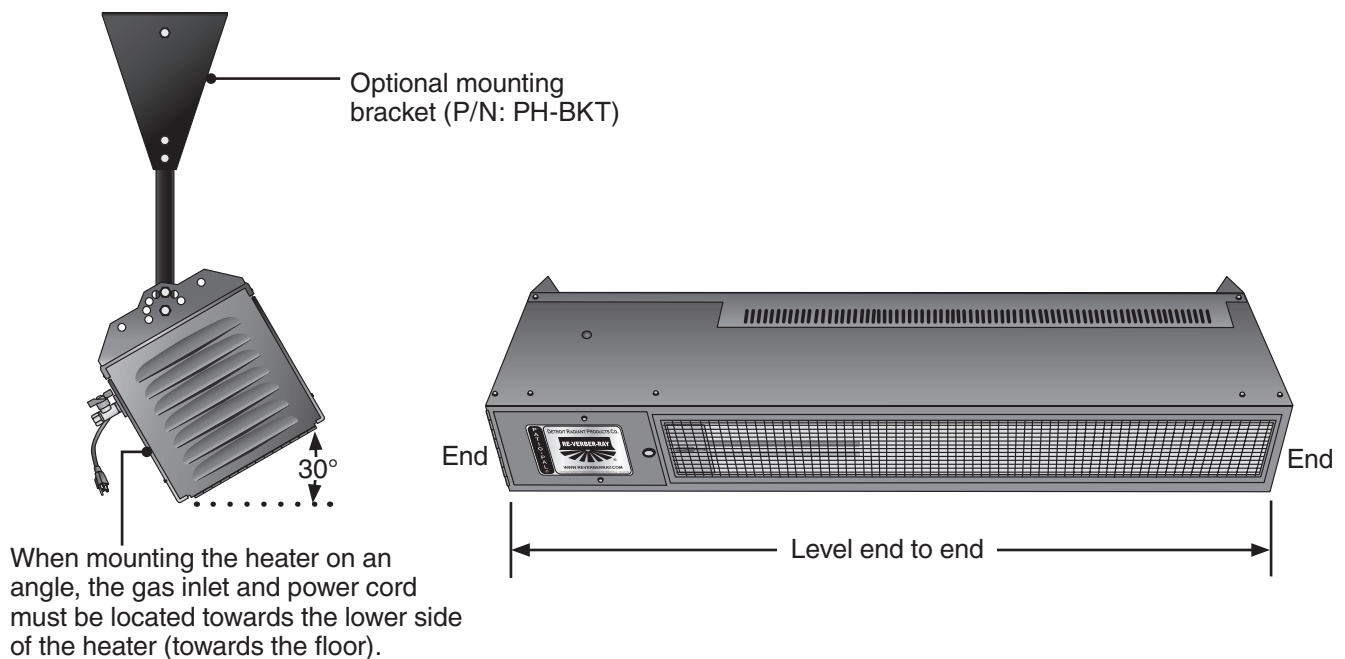

2.0 Installation • Heater Mounting

Figure 2.4 shows different types of mounting configurations. Depending on the type of mounting you use, be sure to:

- 1 Prepare mounting surface. If necessary, weld blocks to mounting structure, drill holes, etc.
- 2 Fasten beam clamp, screw hook or other type of suspension anchor to hanging point.
- 3 Attach and close S-Hook (P/N: S-HOOK) and #1 double-loop chain (P/N: THCS includes a 5 ft. chain and 2 S-hooks, 4 required) to anchor. Check that it is securely attached.
- 4 Attach heater to chains. Adjust chain lengths until the heater is level and equal weight distribution is achieved. Chains must be straight up and down, do not install chains at an angle.

Figure 2.4 • Heater Mounting

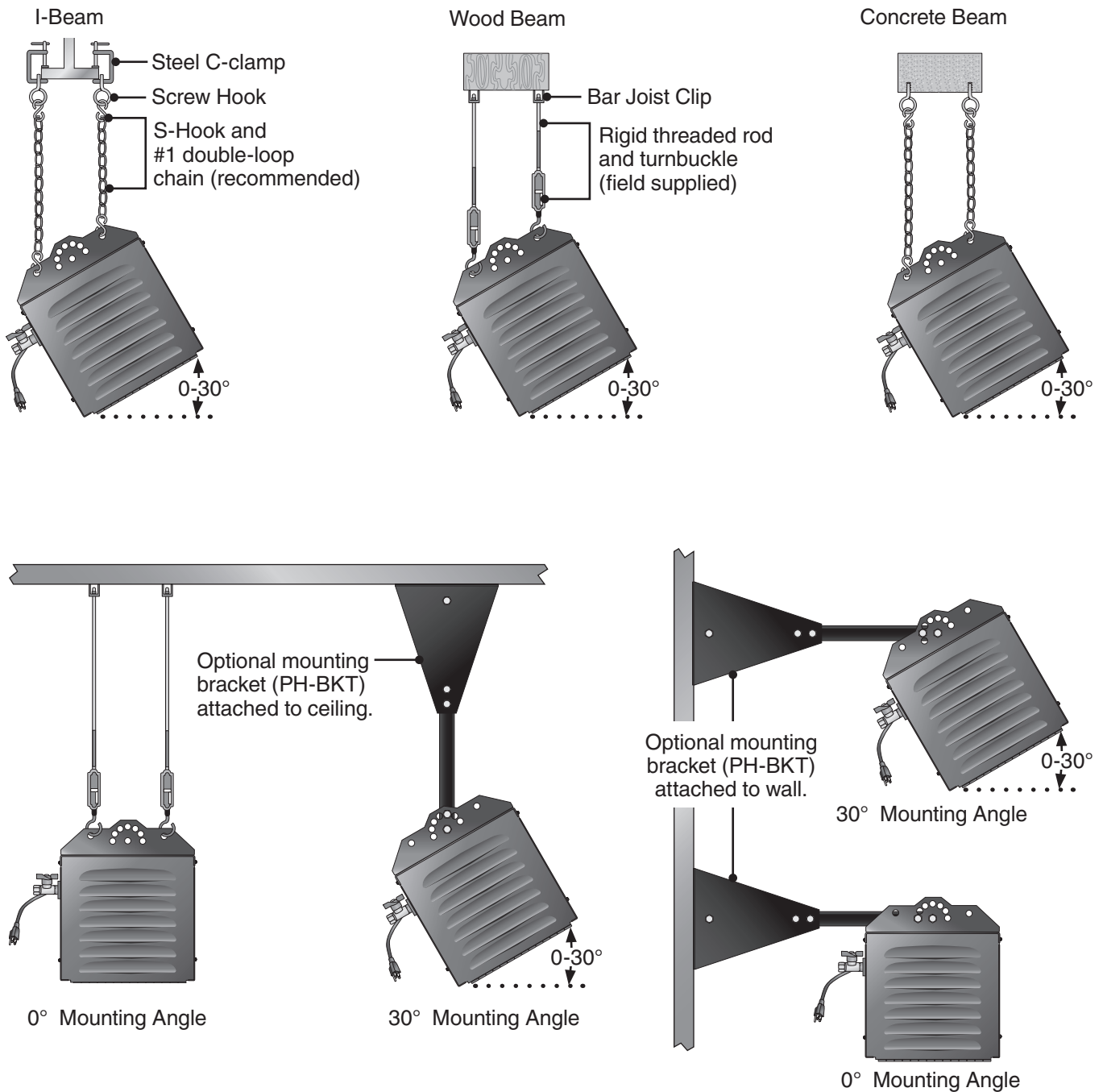

Gas Supply

⚠ WARNING



Improperly connected gas lines may result in fire, explosion, poisonous fumes, toxic gases, asphyxiation and death. Connect gas lines in accordance to national, state, provincial and local codes.

The gas supply to the infra-red heater must be connected and tested in accordance with national, state, provincial and local codes along with the guidelines in the Detroit Radiant PH Series manual. Refer to the latest edition of the ANSI Z223.1 (NFPA 54) Standard.

Important! Before connecting the gas supply to the infra-red heater(s):

- Check for conditions such as drafts or other variables which might cause excessive movement of the unit and cause damage to the gas connection. Ensure that the unit is securely mounted and connect the gas with an approved connection device suitable for the environment of use.
- Check that the gas piping and service has the capacity to handle the load of all heaters being installed, as well as any other gas appliances being connected to the supply line.
- Check that the main gas supply line is of proper diameter to supply the required fuel pressures.
- If utilizing used pipe, verify that its condition is clean and comparable to a new pipe. Test all gas supply lines in accordance with local codes.
- Test and confirm that inlet pressures are correct. Refer to the rating plate for required minimum and maximum pressures (see Chart 2.2). The gas supply pipe must be of sufficient size to provide the required capacity and inlet pressure to the heater (if necessary, consult the local gas company).
- For test pressures in excess of 1/2 psig (3.5 kPa), the heater and ball shutoff valve must be disconnected from the gas supply piping system during any pressure testing of the system.
- For test pressures equal to or less than 1/2 psig (3.5 kPa), the heater must be isolated from the gas supply piping system by closing it's individual manual shutoff valve during any pressure testing of the gas supply piping system.

Chart 2.2 • Manifold Pressure

Type of Gas	Required Manifold Pressure	Minimum Inlet Pressure	Maximum Inlet Pressure
Natural	5.0 in. W.C.P.	6.0 in. W.C.P.	14.0 in. W.C.P.
Liquefied Petroleum	10.0 in. W.C.P.	11.0 in. W.C.P.	14.0 in. W.C.P.

Note: Check manifold pressure at the tap on the ball shutoff valve. Readings will be above atmospheric pressure during operation.

Pressure Equivalents: 1 in. W.C.P. equals .058 oz./sq. in. equals 2.49 Mbar.

To connect the gas:

⚠ WARNING



Failure to install, operate or service this appliance in the approved manner may result in property damage, injury or death. This heater must be installed and serviced by trained gas installations and service personnel only.

The installation of this heater must conform with local building codes or, in the absence of such codes, the National Fuel Code (NFPA 54).

The gas outlet must be in the same room as the appliance and accessible. It may not be concealed within or run through any wall, floor or partition.

- 1 Install a sediment trap / drip leg if condensation may occur at any point of the gas supply line. This will decrease the possibility of loose scale or dirt in the supply line entering the heater's control system and causing a malfunction. **Note:** High pressure gas above 14 in. W.C.P. (water column pressure) requires a high pressure regulator and ball valve (field supplied).
- 2 A stainless steel flexible hose (field supplied) formed into a smooth C-shape is recommended (Figure 2.5). If local codes prohibit the use of a gas hose, then a swing joint may be used.
- 3 Attach the ball valve (field supplied) to the gas supply pipe. Apply pipe compound to NPT adapter threads to seal the joint. Use only a pipe compound resistant to liquid petroleum.
Note: Provide a 1/8 in. NPT plugged tapping accessible for test gauge connection immediately upstream of gas connection to the heater (provided on ball valve, when supplied).
- 4 Attach a gas connector (field supplied) to the adapter and the heater's gas inlet. Seal the joints.
Important! The fittings (nuts) on the flexible connector (field supplied) must be connected to an adapter. They may not be directly connected to the gas supply pipe.
Excessive torque on the manifold may misalign the orifice. **Always** use two wrenches to tighten mating pipe connections.
- 5 Final assembly must be tested for gas leaks according to NFPA or local codes.

⚠ WARNING



Testing for gas leaks with an open flame or other sources of ignition may lead to a fire or explosion and cause serious injury or death. Test in accordance with NFPA or local codes.

To disconnect the gas:

- 1 Disconnect the power to the heater.
- 2 Turn off the gas supply to the heater and "bleed" the gas line.
- 3 Using two wrenches, slowly loosen the fittings. Excessive torque on the manifold may misalign the orifice.
- 4 Inspect the hose and fittings for abrasion, wear or damage. Replace if necessary.

⚠ WARNING



Failure to disconnect the electricity to the heater before disconnecting the gas supply may result in explosion, fire, property damage, injury or death.

⚠ WARNING



Conditions such as wind drafts or other variables can cause movement of the heater and may require it to be rigidly mounted. Avoid excessive movement and/or vibration of the gas connection by rigidly mounting the heater.

Figure 2.5 • Gas Connection (shown installed with a flexible hose)

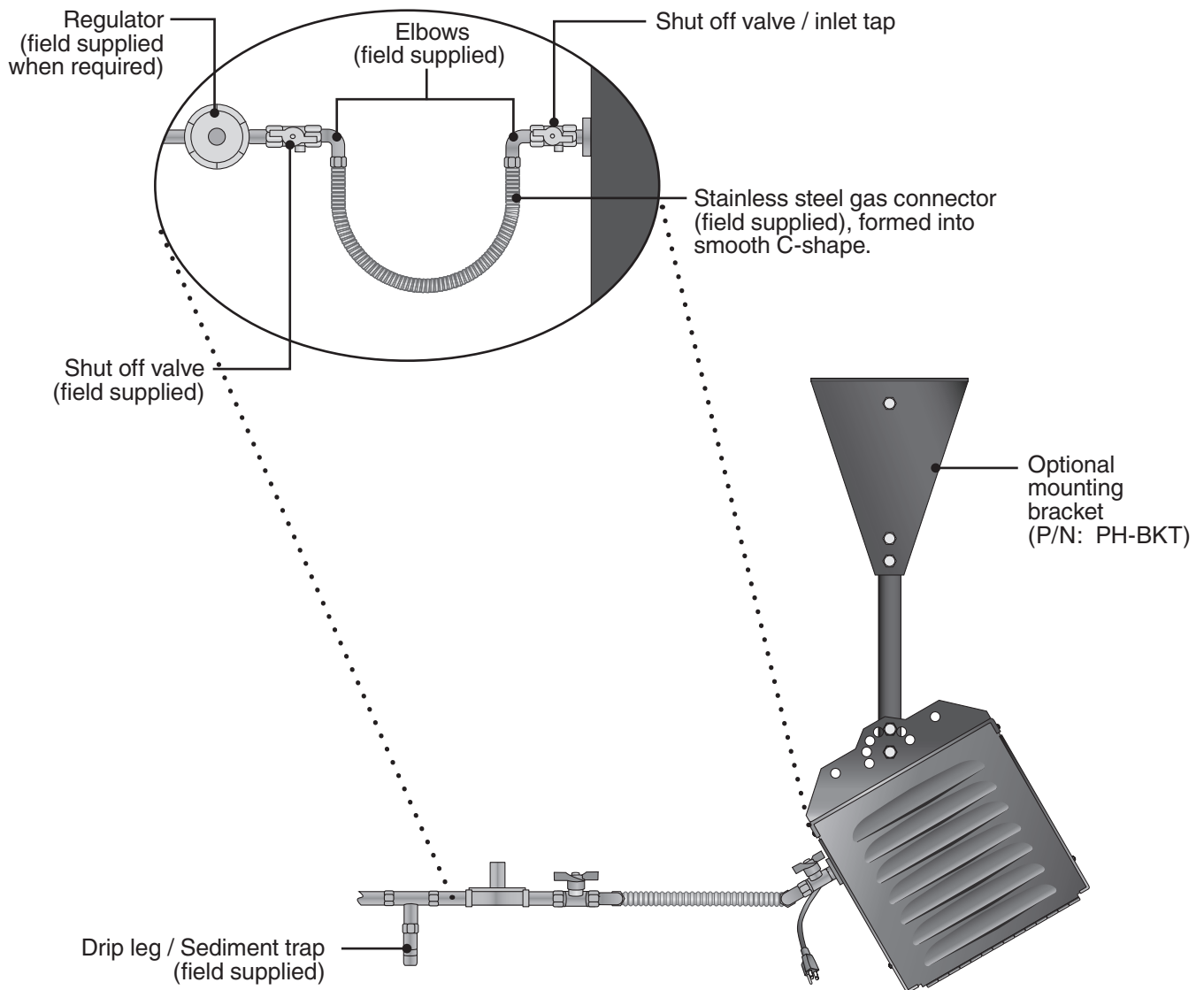

Electrical Requirements

⚠ WARNING



Incorrect or improper wiring may result in shock, injury or death. Field wiring to the heater must be connected and grounded in accordance with national, state, provincial, local codes and to the guidelines in this manual. Refer to the most current revisions to the ANSI/NFPA 70 Standard.

NOTICE

Radiant heat may damage the flexible power cord. Always keep the flexible power cord away from the heater. Do not allow the power cord to be subjected to radiant heat.

Control systems are initiated by either 120V or optional 24V control voltage. A 120V system can be operated directly with 120V to the heater. Heaters with the optional relay can be controlled with 24V. Transformers (sold separately) must be used to supply power of sufficient VA rating for single or multiple connected installations.

Important! Proper grounding and polarity are essential. If the system is not properly grounded, it cannot determine the presence of a flame and will lockout and shut off.

For wiring of controls see Figure 2.7 below. It is recommended that the control be installed on the hot side of a fused supply line and have a sufficient ampere capacity rating for the heater(s) it will control (see Figures 3.1 & 3.2).

Figure 2.7 • Typical Field Wiring

PH Series 120V

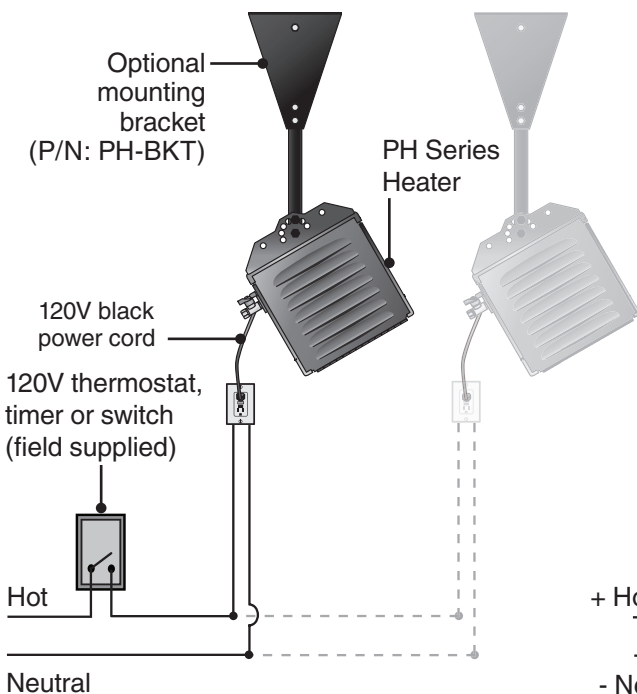

PH Series 120V with 24V Control (PH-24VAO)

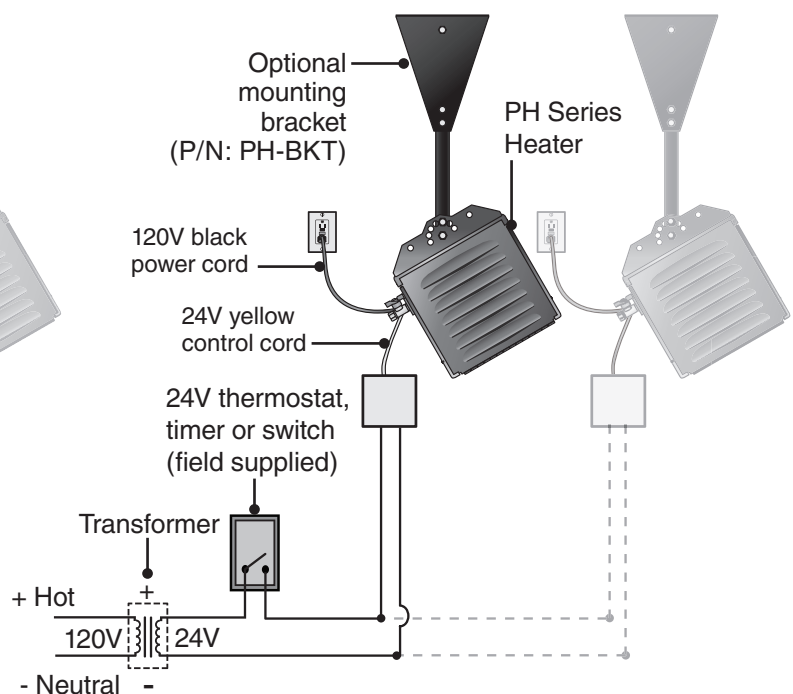

Ventilation

⚠ WARNING

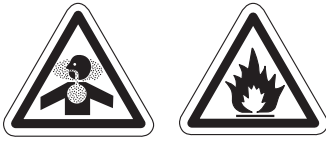

Improper or insufficient ventilation may result in explosion, fire, health problems, carbon monoxide poisoning or death. Vent enclosed spaces and buildings according to national, state, provincial and local codes.

This infra-red heater must be vented in accordance with national, state, provincial and local codes and the guidelines in the Detroit Radiant PH Series manual. Refer to the latest edition of the ANSI Z223.1 (NFPA 54) Standard.

It is required that the upper levels of the space to be heated are properly ventilated to supply combustion air to the heaters and to sufficiently dilute the products of combustion. It is also important to keep the flue discharge area clear of gas piping and electrical wiring (see Figure 2.6).

Provisions must also be made to provide sufficient fresh air intake area and exhaust air outlet area. Natural or mechanical means shall be provided to supply and exhaust at least 4.0 CFM per 1000 BTU/H of gas input. Exhaust openings for the removal of flue products must be above the level of the heater(s).

Where insufficient air movement exists, induced air displacement is required. A balanced system is essential to avoid negative building pressure which causes excessive infiltration, unfavorable drafts and affects combustion efficiency.

Air displacement may be accomplished by either gravity or mechanical means. Mechanical exhausters are preferred and typically mounted at high points on the roof over where stagnant air accumulates inside. For a flat roof, considerations of prevailing winds, high and low pressure areas, and distribution of air movement must be taken into consideration when locating exhausters.

Best air distribution is accomplished by using a number of small exhausters versus one large exhauster. Provide a minimum of one square inch of inlet area per 1000 BTU/H for combustion air supply. Inlet opening in the building should be well distributed, located high on the wall and should direct incoming air upward to dilute products of combustion while preventing drafts at lower levels. Inlets are typically 1 to 3 sq. ft.

In certain applications, local codes may require that mechanical exhaust systems be interlocked with the heaters to enable both to function simultaneously or allow control of exhausters with a ceiling mounted humidistat.

Figure 2.6 • Hot Flue Discharge

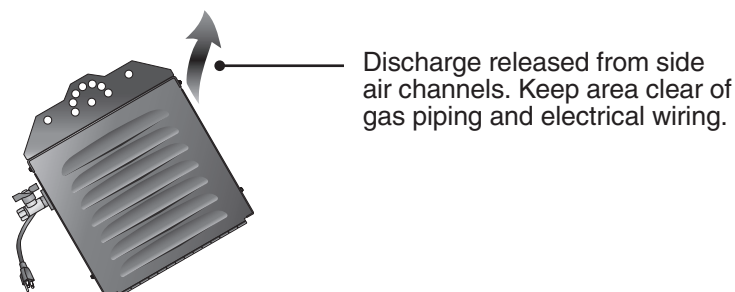

3.0 Operation

⚠ WARNING



Improper operation of the heater may result in explosion, fire, shock and carbon monoxide poisoning. Follow all guidelines and warnings in this manual and national, state, provincial and local codes. Always conduct safety checks before operating the heater. Do not operate the heater in unsafe conditions.

Important! Before operating the heater, conduct the following safety procedures:

- Check for any possible gas leaks.
- Alert all persons about the hazards of high surface temperature and to keep a safe distance away in order to avoid burns and possible clothing ignition.
- Provide supervision when young children are in the area of the heater.
- Check to make sure clothing isn't hung from the heater and that flammable materials are not placed on or near the heater.
- Check that all guards or protective devices are in place and secure.
- Check the hose assembly for excessive abrasion, wear or damage. If necessary replace. The replacement hose **must** be that specified by Detroit Radiant Products.
- Check control compartment, burners and circulating air passages for debris. If necessary, clean the debris.

Sequence of Operation:

Starting Circuit:

When voltage is applied to L1 and L2, a circuit is completed from L1 via the blower motor to L2. The blower fan is mounted in the control box and rated to supply sufficient air for combustion. Air pressure generated by the blower will cause the normally open pressure switch to close. Another circuit is completed from L1 to the spark ignition module and back to L2. After a seven (7) second pre-purge, the spark electrode and gas valve are energized simultaneously. The trial for ignition is fifteen seconds.

Running Circuit:

After ignition, the flame rod monitors the flame. As long as a flame is present, the valve is held open. If the flame is lost, the control acts to close the valve within one second, and a new trial sequence identical to that at start-up is initiated. If proof of flame is not established within the 15 second trial for ignition, the unit will retry two additional times before entering lockout mode. If lockout occurs, the control can be reset by briefly interrupting the power source.

Lighting Instructions:

- ❶ Rotate heater’s valve knob to “ON” position.
- ❷ Close electrical circuit (usually thermostat).
- ❸ If the heater fails to light, turn “OFF” gas, open electrical circuit and wait 5 minutes before repeating.

Shutdown Instructions:

- ❶ Open electrical circuit (usually thermostat).
- ❷ Turn off electrical power if service is to be performed.
- ❸ Rotate heater’s valve knob to “OFF” position.

Wiring Diagrams

Figure 3.1 • PH Series 120V

Amp draw:
120V - .25 starting, .24 running

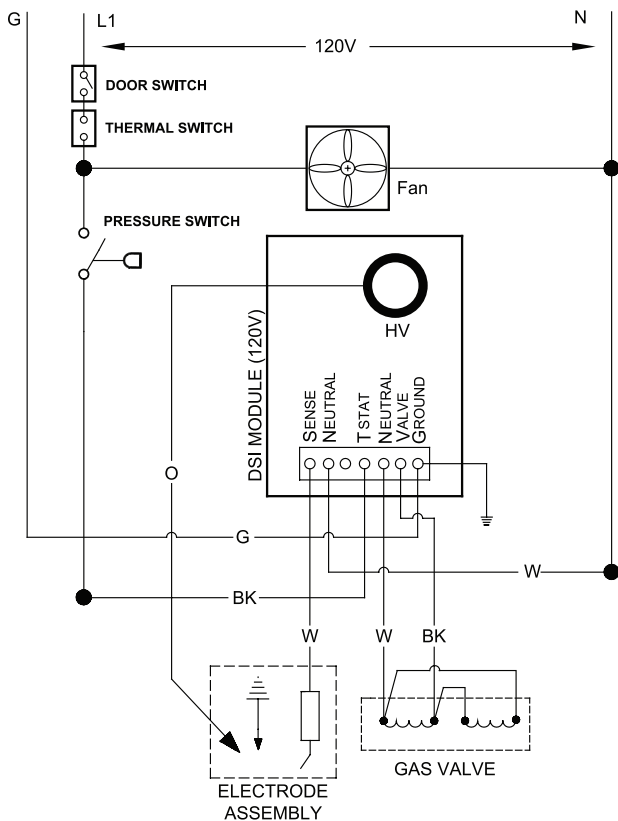
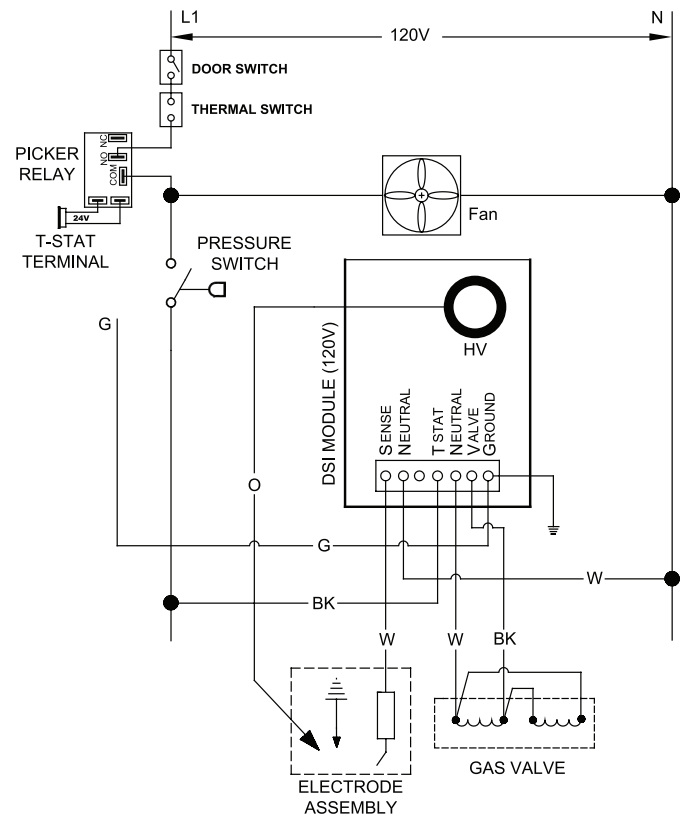

Figure 3.2 • PH Series 120V with 24V control

Amp draw:
24V - .10 starting.
120V - .25 starting, .24 running.



4.0 Maintenance

⚠ WARNING



Always wear clothing that protects the body and use protective glasses when maintaining the heater.

Electrical shock or explosion may occur when conducting maintenance while the heater is connected to the power source and gas supply. Disconnect power and gas supply to heater before servicing.

Burner malfunction may result in explosion or fire. Never operate the heater if there are any signs of malfunction, excessive wear or damage. Call a professional for assistance.

NOTICE

Cleaning the heater elements with high pressure air may cause damage to the elements and equipment failure. Do not blow out heating elements with high pressure air.

Before each use:

- Check the gas supply line and hose assembly for any possible leaks or damage.
- Check heater elements for debris. Visually check burner flames.
- Keep the heated area clear and free of combustible materials, gasoline and flammable vapors and liquids. Ensure there is no obstruction of the flow of combustion and ventilation.

Periodic maintenance:

- Clean the heater with cleaning agents suitable for the unit's construction material (i.e., stainless steel cleaner).
- Lubricate moving parts.
- Inspect the gas supply piping system for signs of corrosion or failure. Replace if necessary.

Before conducting maintenance on the heater disconnect the power and gas supply. When pressure testing the gas supply piping system follow these guidelines:

- At a test pressure in excess of 1/2 psig (3.5 kPa) the heater and ball shutoff valve must be disconnected from the gas supply piping system during any pressure testing of the system.
- At a test pressure equal to or less than 1/2 psig (3.5 kPa) the heater must be isolated from the gas supply piping system by closing it's individual manual shutoff valve during any pressure testing of the gas supply piping system.

Cleaning the main burner:

- ① Gently use an air hose to blow any accumulated dust and/or dirt off the heater. **Air hose pressure should not exceed 30 psig.**
- ② Gently, pass the air hose over the entire exposed area of the ceramic. **A distance of 2' to 4' from the unit is recommended.**
- ③ Gently place the air hose outlet into the venturi tube and allow the air to flow for approximately one minute.

During long periods of non-usage, remove or cover heater with a polyethylene bag and shut off gas supply. If further service to the heater is desired, contact your representative or the factory.

Chart 4.1 • Troubleshooting Guide

Symptom	Possible Cause	Corrective Action
Burning of gas-air mixture inside plenum (flashback).	<ul style="list-style-type: none"> • Heater mounted at incorrect angle. • Excessive drafts. • Gas leaking at orifice. • Separation of ceramic grids. • Ceramic grids cracked. 	<ul style="list-style-type: none"> • Mounting angle 0° - 30°. • Relocate or shield from draft. • Check with leak detector solution. • Replace burner. • Replace burner.
Delayed ignition.	<ul style="list-style-type: none"> • Electrode out of specification. • Low gas pressure. • Partially blocked orifice. • Improper orifice size. • Incorrect gas. 	<ul style="list-style-type: none"> • See ignition system insert. • See Section 2.0, Gas Supply. • Clean or replace. • Consult Dealer. • See unit nameplate.
Low ceramic surface temperature or excessive rollout.	<ul style="list-style-type: none"> • Dirty or plugged burner ceramics. • Partially blocked orifice. • Low inlet gas pressure. • High or low manifold gas pressure. • Foreign matter in venturi tube. • Excessive dark spots on burner. • Gas supply piping too small. • Incorrect gas. 	<ul style="list-style-type: none"> • See periodic maintenance instructions. • Remove and clean. • See Section 2.0, Gas Supply. • Adjust main valve regulator as specified. • See periodic maintenance instructions. • See periodic maintenance instructions. • Increase inlet pressure or replace piping. • See unit nameplate.
Control system overheating.	<ul style="list-style-type: none"> • Heater not mounted correctly. • Heater mounted too close to ceiling. 	<ul style="list-style-type: none"> • Mounting angle 0° - 30°. Level left to right. • Observe clearance to combustibles.
Gas odor.	<ul style="list-style-type: none"> • Loose pipe connection. 	<ul style="list-style-type: none"> • Check connections. Tighten as necessary.
Heater cycles repeatedly.	<ul style="list-style-type: none"> • Heater located in drafty area. • Low gas pressure. • Thermostat located in drafty area. • Defective flame electrode or circuit board. 	<ul style="list-style-type: none"> • Relocate or shield from draft. • See Section 2.0, Gas Supply. • Relocate thermostat. • Replace.
No spark; no ignition.	<ul style="list-style-type: none"> • Lack of 120V or 24V incoming voltage. • Open high voltage wire. • Fan not operating. • Improper electrode gap. • Loose or open wire connection. • Pressure switch not satisfied. • Poor or no equipment ground. • Unit in “safety lockout” mode. • Defective “gaslighter” control. 	<ul style="list-style-type: none"> • Check power supply. • Isolate an ohm for resistance, replace if 0. • Locate source of electrical problem or replace faulty fan. • See Ignition System specifications. • Check all wires, tighten or replace. • Verify fan operation. Remove obstructions. • Check all connections, provide positive earth ground. • Interrupt power source, repeat trial for ignition. • Replace.
Heater lights, and “locks out” after approximately 10 seconds.	<ul style="list-style-type: none"> • Poor or no equipment ground. • Polarity is reversed. • Low gas pressure. • Electrode not sensing. • Heater mounted at incorrect angle. • Defective “gaslighter” control. 	<ul style="list-style-type: none"> • Check all connections, provide positive earth ground. • 120V to black, neutral to white. • See Section 2.0, Gas Supply. • Relocate or replace if defective. • Mounting angle 0° - 30°. • Replace.
Spark is present. No main gas operation. Unit “locks out”.	<ul style="list-style-type: none"> • Gas valve in “OFF” position. • Defective gas valve. • Defective “gaslighter” control. 	<ul style="list-style-type: none"> • Turn to “ON” position. • Isolate and check for resistance, replace if 0. • Replace.
Heater will not shut off.	<ul style="list-style-type: none"> • Defective thermostat or wiring. • Gas valve stuck or open. • High gas pressure. 	<ul style="list-style-type: none"> • Replace or repair. • Replace. • See Section 2.0, Gas Supply.

5.0 Parts

Figure 5.1 • Components

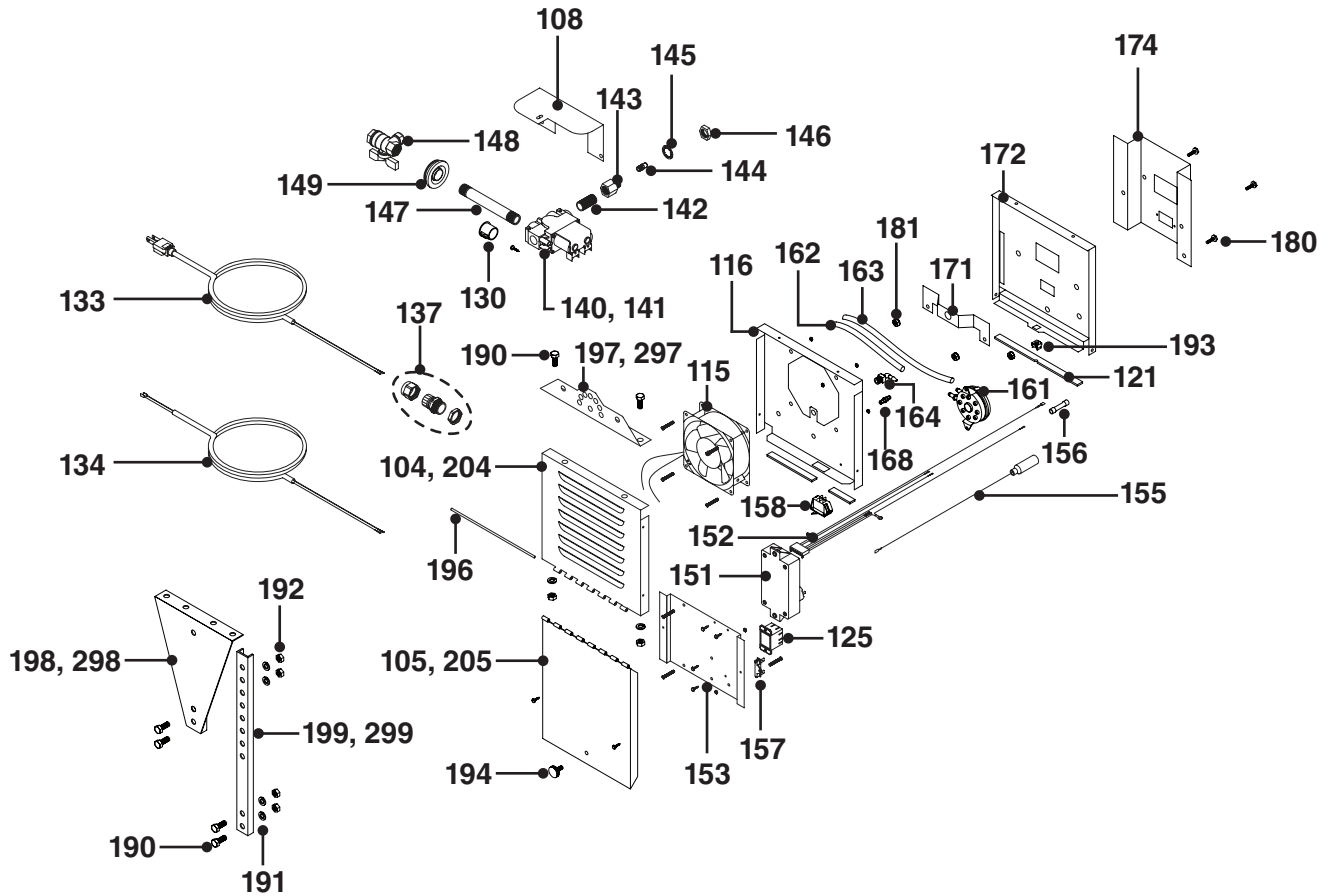

PART#	DESCRIPTION	PART#	DESCRIPTION
PH-101	Top Panel	PH-134	Optional 24V Cord Set
PH-102	Left Frame Side Panel (Gas & Electric)	PH-137	Strain Relief (TP-68B)
PH-103	Right Frame Side Panel	PH-140	Gas Valve - Natural Gas
PH-104	Control End Panel w/ Louvers & Hinge	PH-141	Gas Valve - Propane
PH-105	Control Box Cover w/ Hinge	PH-142	3/8" Closed Pipe Nipple
PH-106	End Panel	PH-143	3/8" Reducer Fitting (TP-56)
PH-108	Valve Mounting Base	PH-144	Gas Orifice (Specify Model)
PH-110	Rain Guard	PH-145	9/16" Ext. Lock Washer
PH-111	8" x 35" Egg Crate (PH-EC)	PH-146	9/16"-18 Hex Jam Nut
PH-112	Egg Crate Frame w/ Flashshield	PH-147	3/8" x 5" Inlet Pipe Nipple
PH-113	Egg Crate Assembly w/ Frame & Nutsert	PH-148	3/8" Ball Valve/Inlet Tap
PH-115	120 Volt Fan	PH-149	Rubber Inlet Grommet
PH-116	Fan Mounting Panel	PH-150	Ignitor Electrode
PH-117	Air Distribution Panel	PH-151	Circuit Board (MARK 10DX-117)
PH-121	Weather Stripping	PH-152	100-900 Harness (DRWH-120)
PH-122	3/8" Black Inlet Pressure Tap Grommet	PH-153	Controls Mounting Panel
PH-125	Optional Picker Relay	PH-155	12" Orange High Voltage Wire w/ Boot
PH-130	3/4" Black Plastic Inlet Cap	PH-156	2-Way Red Crimp Connector
PH-133	120V Cord - 3 Ft.	PH-157	Thermal Switch

To order replacement parts call Detroit Radiant Products at: voice (586) 756-0950, fax: (586) 756-2626 or visit our website: www.reverberray.com/parts

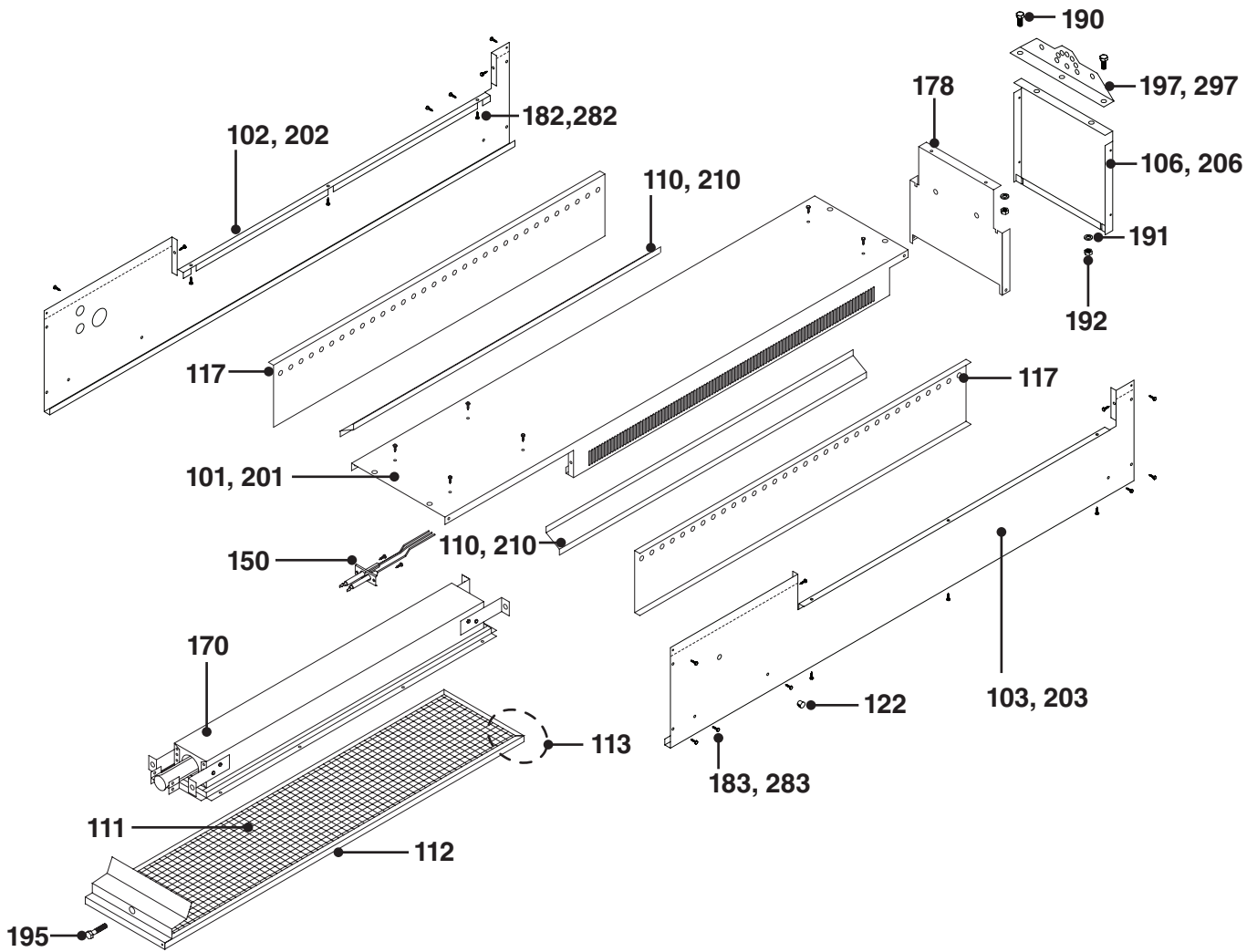

PART#	DESCRIPTION	PART#	DESCRIPTION
PH-158	Door Switch	PH-194	Control Cover Thumbscrew
PH-161	Pressure Switch (TP-264B)	PH-195	#5/16-18 x 1-1/2" Gold Nutsert Bolt
PH-162	Short Vinyl Hose - 4.5"	PH-196	Control Cover Hinge Rod
PH-163	Long Vinyl Hose - 9.0"	PH-197	Hanging Bracket (Black)
PH-164	Plastic Gas Valve 90° Vent (TP-245)	PH-198	Wall Bracket Assembly (Black) - Optional
PH-168	Brass Fitting (TP-97)	PH-199	Support Channel (Black) - Optional
PH-170	Burner Assembly w/ Hold-Downs & Footings	STAINLESS STEEL PARTS	
PH-171	Valve Mounting Bracket	PH-201	Top Panel (SS)
PH-172	Valve Mounting Panel	PH-202	Left Frame Side Panel (Gas & Electric) (SS)
PH-174	Burner & Electrode Mounting Panel	PH-203	Right Frame Side Panel (SS)
PH-178	Burner End Mounting Panel	PH-204	Control End Panel w/ Louvers & Hinge (SS)
PH-180	#1/4-20 x 1/2" Machine Bolt (DR-20MB)	PH-205	Control Box Cover w/ Hinge (SS)
PH-181	#1/4-20 Hex Nut (DR-20HN)	PH-206	End Panel (SS)
PH-182	#8 x 1/2" SLTD HW Screw (Standard)	PH-210	Rain Guard (SS)
PH-183	#8 x 1/2" SLTD HW Screw (Black)	PH-282	#8 x 1/2" SLTD HW Screw (SS)
PH-190	5/16" x 3/4" Hex HD Bolt	PH-283	#8 x 1/2" SLTD HW Screw (Black or Plated Stainless)
PH-191	5/16" Split Washer Zinc	PH-297	Hanging Bracket (SS)
PH-192	5/16" Hex Nut	PH-298	Wall Bracket Assembly (SS)
PH-193	#1/4-20 Square Cagenut	PH-299	Support Channel (SS)

Note: (SS) denotes parts available in stainless steel.

6.0 Limited Warranty

One-Year Limited Warranty. Patio Heaters covered in this manual, are warranted by Detroit Radiant Products Company to the original user against defects in workmanship or materials under normal use for one year after date of purchase. Any part which is determined to be defective in material or workmanship and returned to an authorized service location, as Detroit Radiant Products Company designates, shipping costs prepaid, will be, as the exclusive remedy, repaired or replaced at Detroit Radiant Products Company's option. For limited warranty claim procedures, see PROMPT DISPOSITION below. This limited warranty gives purchasers specific legal rights which vary from jurisdiction to jurisdiction.

Additional Limited Warranty. In addition to the above mentioned one-year warranty, Detroit Radiant Products Company warrants the original purchaser an additional two-year extension on the ceramic burner. This extension excludes electrical/purchased components.

Limitation of Liability. To the extent allowable under applicable law, Detroit Radiant Products Company's liability for consequential and incidental damages is expressly disclaimed. Detroit Radiant Products Company's liability in all events is limited to and shall not exceed the purchase price paid.

Warranty Disclaimer. Detroit Radiant Products Company has made a diligent effort to provide product information and illustrate the products in this literature accurately; however, such information and illustrations are for the sole purpose of identification, and do not express or imply a warranty that the products are merchantable, or fit for a particular purpose, or that the products will necessarily conform to the illustrations or descriptions. Except as provided below, no warranty or affirmation of fact, expressed or implied, other than as stated in the "LIMITED WARRANTY" above is made or authorized by Detroit Radiant Products Company.

Product Suitability. Many jurisdictions have codes and regulations governing sales, construction, installation, and/or use of products for certain purposes, which may vary from those in neighboring areas. While Detroit Radiant Products Company attempts to assure that its products comply with as many codes, it cannot guarantee compliance, and cannot be responsible for how the product is installed or used. Before purchase and use of a product, review the product applications, and all applicable national and local codes and regulations, and be sure that the product, installation, and use will comply with them.

Certain aspects of disclaimers are not applicable to consumer products: e.g., (a) some jurisdictions do not allow the exclusion or limitation of incidental or consequential damages, so the above limitation or exclusion may not apply to you: (b) also, some jurisdictions do not allow a limitation on how long an implied warranty lasts, consequently the above limitation may not apply to you: and (c) by law, during the period of this limited warranty, any implied warranties of implied merchantability or fitness for a particular purpose applicable to consumer products purchased by consumers, may not be excluded or otherwise disclaimed.

Prompt Disposition. Detroit Radiant Products Company will make a good faith effort for prompt correction or other adjustment with respect to any product which proves to be defective within limited warranty. For any product believed to be defective within limited warranty, first write or call dealer from whom the product was purchased. Dealer will give additional directions. If unable to resolve satisfactorily, write to Detroit Radiant Products Company at address below, giving dealer's name, address, date and number of dealer's invoice, and describe the nature of the defect. Title and risk of loss pass to buyer on delivery to common carrier. If product was damaged in transit to you, file claim with carrier.

Registration. Register on-line at www.detroitradiant.com/warranty.

© 2008 Detroit Radiant Products Company

21400 Hoover Road Warren, MI 48089 U.S.A.

Voice: (586) 756-0950

Fax: (586) 756-2626

Website: www.detroitradiant.com